

SUBMITTAL RECORD

JOB _____
 LOCATION _____
 SUBMITTED TO _____
 SUBMITTAL PREPARED BY _____
 APPROVED BY _____
 DATE _____



**Submittal Form
 Y Toggle - Kits**

DESCRIPTION

A toggle hanger is used for hanging fluorescent light troffers and other lighting applications. Different lengths are available, with RWC2 cable. Toggles are offered in three styles; Y shape, V shape and single strand. We also offer toggles in a kit.

For ordering information, see reverse side.

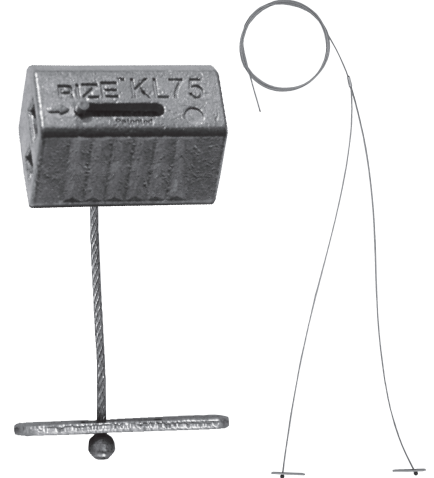
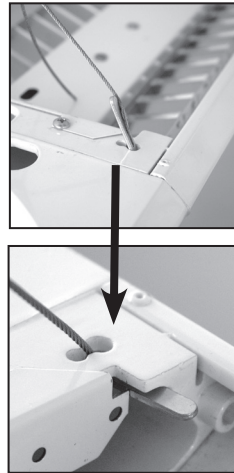
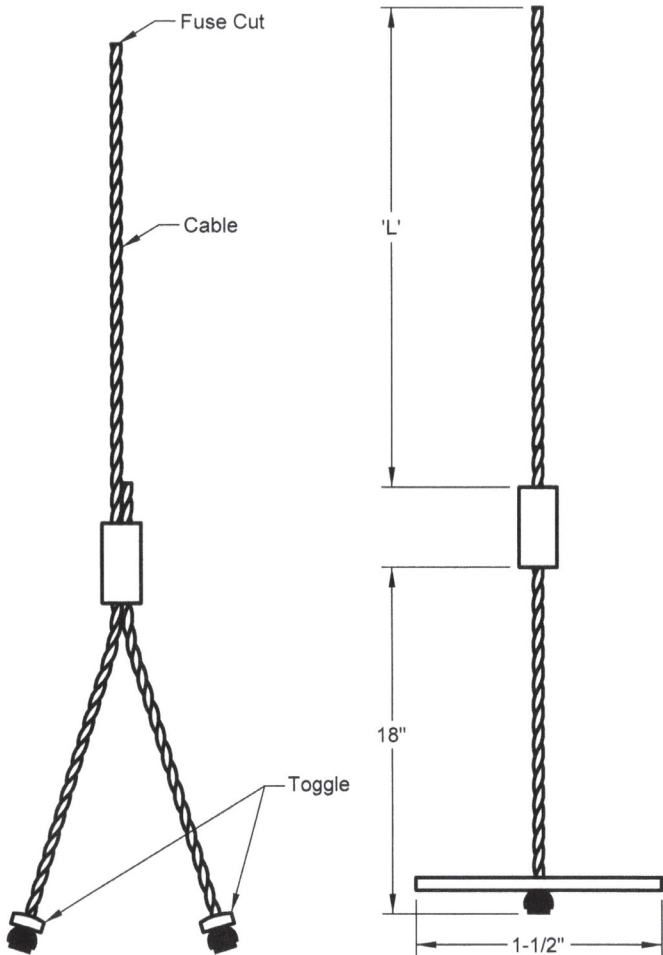

SUGGESTED SPECIFICATION:

All ductwork and equipment shall be supported using wire rope cable terminated by Cable Locks. All Cable Locks shall have an Ultimate Breaking Strength (U.B.S.) of at least 5 times the published Working Load Limit (W.L.L.). Wire ropes shall be of the size and spaced per manufacturers printed specifications. Wire Rope and Cable Locks shall be as supplied by Rize Enterprises, LLC.

SPECIFICATION DATA

- 1) All wire rope supplied by Rize is statistically tested to minimum breaking strength.
- 2) Rize Suspension System has been submitted and tested to be an acceptable alternative to the duct hanger systems prescribed in SMACNA HVAC-DCS 2nd edition By SMACNA Testing & Research Institute.
- 3) All Working Load Ratings of Rize Kwik-Locs manufactured by Rize have been witnessed and verified by Independent Testing Labs.
- 4) Rize Kwik-Locs may be used in temperatures up to 300 degrees F.
- 5) Rize Kwik-Locs wedges are constructed of corrosion resistant sintered steel.
- 6) Rize Kwik-Loc springs are constructed of tempered stainless steel.

**WIRE ROPE SPECIFICATION
 CARBON STEEL & GALVANIZED**

Galvanized steel wire rope, supplied by Rize is manufactured to exacting standards and statistically tested to verify the breaking strength. Rize recommends only using wire rope supplied by Rize. The chart below outlines the specifications.

Wire Rope Size	Tolerance	Rope Construction	Min. Breaking Strength
RWC2	+ .010/- .005 in.	7x7	480 lbs.

**APPLICABLE SMACNA STANDARD
 4.2.11 Hanging System Selection**

The selection of a hanging system should not be taken lightly not only because it involves a significant portion of the erection labor, but also because an inadequate hanging system can be disastrous. In any multiple hanging system, the failure of one hanger transfers that load to adjacent hangers. If one of these fail, an even greater load is transferred to the next. The result is a cascading failure in which an entire run of duct might fail.

There are many hanger alternatives, especially in the upper attachments. Besides structural adequacy, the contractor's choice of hanging system must also take into account the particulars of the building structure, the skills of the worker, the availability of tooling, and the recommendations of the fastener manufacturer. Because of these variables, it is suggested that the hanging system be the contractor's choice, subject to the approval of the mechanical engineer.

See reverse side for Rize testing and warnings

SUBMITTAL RECORD
 JOB _____
 LOCATION _____
 SUBMITTED TO _____
 SUBMITTAL PREPARED BY _____
 APPROVED BY _____
 DATE _____



Submittal Form Toggle

Toggle Kits					
Item #	Code	Description	For Use w/ Cable Lock	Safe Working Load*	Quantity
30274	RWC2Y12P10K	(2) RWC2 x 10ft 12" Y Toggle & (2) KL75 Kit	KL75	10-75 lbs.(5-34 kg)	10 bags/ctn
30194	RWC2Y18P5K	(2) RWC2 Cable 5ft.-18" Y Toggle & (2) KL75 Kit	KL75	10-75 lbs.(5-34 kg)	10 bags/ctn
30202	RWC2Y18P10K	(2) RWC2 Cable 10ft.-18" Y Toggle & (2) KL75 Kit	KL75	10-75 lbs.(5-34 kg)	10 bags/ctn
30205	RWC2Y18P15K	(2) RWC2 Cable 15ft.-18" Y Toggle & (2) KL75 Kit	KL75	10-75 lbs.(5-34 kg)	5 bags/ctn
30200	RWC2Y18P20K	(2) RWC2 Cable 20ft.-18" Y Toggle & (2) KL75 Kit	KL75	10-75 lbs.(5-34 kg)	5 bags/ctn
*Safe Working Loads are based on a 5:1 Safety Factor.					

WARNINGS

ALWAYS CONFIRM ENGAGEMENT OF CABLE LOCK ON WIRE BEFORE APPLYING THE LOAD: By pushing the adjustment pin in the opposite direction of the arrows on the cable lock and then pulling the cable also in the opposite direction of the arrows on the cable lock.

PULL ADJUSTMENT PIN BACK AND PASS WIRE ROPE THROUGH RIZE CABLE LOCK: Failure to pull adjustment pin first may cause damage to serrated teeth and reduce holding capacity.

TO ENSURE HANGING SYSTEM INTEGRITY AND SAFETY: Use only Rize wire rope.

WORKING LOAD LIMIT (WLL) MUST FALL WITHIN THE STATED WORKING LOAD RANGE OF THE CABLE LOCK: Each product is load rated and incorporates a minimum safety factor of 5:1. This WLL takes into account the specification criteria of the Rize Cable Lock and the wire rope.

DO NOT USE ON COATED WIRE ROPE: It is important to maintain the metal to metal contact between the locking pawls in the Kwik-Loc and the wire rope.

SPRAY PAINTING: of the Rize Suspension Hanging System **after** installation is acceptable, at the installing contractor's discretion, **if** the installing contractor physically confirms engagement of each cable lock on the cable prior to and after painting, and in strict accordance with the Rize Installation Instructions. Brush painting is not acceptable. Do not paint Cable or Cable Lock prior to installation. Do not reposition Cable Lock after painting.

DO NOT APPLY LUBRICANT: to any part of the assembly as this will alter the surface nature of the wire rope and attract dirt and debris.

DO NOT USE FOR LIFTING: (Under Hook slings) This product is designed for static load applications only.

KEEP THE PRODUCT CLEAN AND FREE FROM DIRT: Any dirt should be removed from the product prior to assembly.

INSPECT PERIODICALLY: Upon inspection, discard and replace if worn, distorted, or damaged.

REMOVE DAMAGED WIRE ENDS: Using a designated pair of wire rope cutters prior to inserting into the Rize Kwik-Loc.

WHEN INSTALLING RIZE KWIK-LOC CABLE ATTACHMENTS: to buildings or equipment careful consideration must be made to the attachment method and the material being attached to. It is the responsibility of the installer for the proper selection, installation and appropriateness of the attachment to the job specifications and any codes. Rize can give general guidance, but any questions regarding this should ultimately be directed to the project engineer of the job.

FOR DRY LOCATIONS ONLY

DO NOT USE IN CHLORINATED ATMOSPHERES SUCH AS POOLS AND NATATORIUM

GYMNASIUM INSTALLS MUST BE USING LOCKING CABLE LOCKS ONLY

Please see our Rize testing and warnings webpage for the most detailed list of warnings:
<http://rizellc.com/techsupport-testing.html>